

ZAXIS | DASH-5 ULTRASHORT-CLASS EXCAVATORS

ZX75US-5

42.4 kW (56.9 net hp)



HITACHI

Engine

Manufacturer and Model	Yanmar 4TNV98C
Non-Road Emission Standard	EPA Final Tier 4/EU Stage IV
Net Power (ISO 9249)	42.4 kW (56.9 hp) @ 2,000 rpm
Cylinders	4
Displacement	3.3L (202 cu. in.)
Aspiration	Natural
Off-Level Capacity	70% (35 deg.)

Cooling

Variable-speed fan; viscous clutch

Powertrain

2-speed propel with automatic shift

Maximum Travel Speed

Low	3.1 km/h (1.9 mph)
High	5.0 km/h (3.1 mph)
Drawbar Pull	6650 kgf (14,661 lb.)

Hydraulics

Open Center, Load Sensing

Main Pumps 3 variable-displacement axial-piston pumps

Maximum Pump Flow 2 x 72 + 56 L/m (2 x 19 + 15 gpm)

Pilot Pump 1 gear

Maximum Rated Flow 20 L/m (5.3 gpm)

System Relief Pressure 3900 kPa (566 psi)

System Operating Pressure

Implement Circuits 26 000 kPa (3,771 psi)

Travel Circuits 31 400 kPa (4,554 psi)

Swing Circuits 25 200 kPa (3,655 psi)

Controls Pilot levers, short stroke, low effort; hydraulic pilot controls with shutoff lever

Cylinders

Heat-treated, chrome-plated, polished cylinder rods; hardened steel (replaceable bushings) pivot pins

	Bore	Rod Diameter	Stroke
Boom (l)	115 mm (4.5 in.)	65 mm (2.6 in.)	885 mm (34.8 in.)
Arm (l)	95 mm (3.7 in.)	60 mm (2.4 in.)	900 mm (35.4 in.)
Bucket (l)	85 mm (3.3 in.)	55 mm (2.2 in.)	730 mm (28.7 in.)

Electrical

Batteries 2 x 12 volt

Battery Capacity 2 x 450 CCA

Alternator Rating 50 amp

Work Lights 2 halogen (1 mounted on boom and 1 on frame)

DASH-5

Undercarriage

Rollers (each side)

Carrier	1
Track	5

Shoes (each side)

	40
--	----

Track

Adjustment	Hydraulic
Chain	Sealed and lubricated

Swing Mechanism

Swing Speed	10.5 rpm
Swing Torque	16 600 Nm (12,244 lb.-ft.)

Ground Pressure

450-mm (18 in.) Rubber Crawler Pads	39 kPa (5.6 psi)
450-mm (18 in.) Continuous Rubber Belt	39 kPa (5.6 psi)
450-mm (18 in.) Triple Semi-Grouser Shoes	38 kPa (5.4 psi)
600-mm (24 in.) Triple Semi-Grouser Shoes	27 kPa (3.9 psi)

Serviceability

Refill Capacities

Fuel Tank	135L (35.7 gal.)
Cooling System	9.7L (2.6 gal.)
Engine Oil with Filter	12.3L (3.2 gal.)
Hydraulic Tank	56L (15 gal.)
Hydraulic System	103L (27 gal.)
Propel Gearbox (each)	1.2L (1.3 qt.)

Operating Weights

With 0.31-m³ (0.41 cu. yd.), 762-mm (30 in.), 313-kg (691 lb.) Bucket; 2.12-m (6 ft. 11 in.) Arm; 1305-kg (2,877 lb.) Counterweight; 2470-mm (8 ft. 1 in.) Blade; Full Fuel Tank; and 75-kg (165 lb.) Operator

450-mm (18 in.) Rubber Crawler Pads	8143 kg (17,952 lb.)
450-mm (18 in.) Triple Semi-Grouser Shoes	7882 kg (17,377 lb.)
600-mm (24 in.) Triple Semi-Grouser Shoes	8265 kg (18,221 lb.)
450-mm (18 in.) Continuous Rubber Belt	7898 kg (17,412 lb.)

Optional Components

Undercarriage (with the following)

450-mm (18 in.) Rubber Crawler Pads	2903 kg (6,400 lb.)
450-mm (18 in.) Continuous Rubber Belt	2867 kg (6,321 lb.)
450-mm (18 in.) Triple Semi-Grouser Shoes	2851 kg (6,285 lb.)
600-mm (24 in.) Triple Semi-Grouser Shoes	3025 kg (6,669 lb.)
I-Piece Boom (with arm cylinder)	497 kg (1,096 lb.)

Arm with Bucket Cylinder and Linkage

1.62 m (5 ft. 4 in.)	238 kg (525 lb.)
2.12 m (6 ft. 11 in.)	276 kg (608 lb.)

Boom Lift Cylinders (2), Total Weight	178 kg (392 lb.)
Counterweight, Standard	1305 kg (2,877 lb.)

Operating Dimensions

	Arm Length 1.62 m (5 ft. 4 in.)	Arm Length 2.12 m (6 ft. 11 in.)
Arm Digging Force (ISO)	35.5 kN (7,981 lb.)	30.7 kN (6,902 lb.)
Bucket Digging Force (ISO)	46.6 kN (10,476 lb.)	46.6 kN (10,476 lb.)
A Maximum Reach	6.43 m (21 ft. 1 in.)	6.92 m (22 ft. 8 in.)
A' Maximum Reach at Ground Level	6.26 m (20 ft. 6 in.)	6.76 m (22 ft. 2 in.)
B Maximum Digging Depth	4.11 m (13 ft. 6 in.)	4.61 m (15 ft. 1 in.)
B' Maximum Digging Depth at 2.44-m (8 ft.) Flat Bottom	3.75 m (12 ft. 4 in.)	4.32 m (14 ft. 2 in.)
C Maximum Cutting Height	7.21 m (23 ft. 8 in.)	7.61 m (25 ft. 0 in.)
D Maximum Dumping Height	5.12 m (16 ft. 10 in.)	5.51 m (18 ft. 1 in.)
E Minimum Swing Radius	1.81 m (5 ft. 11 in.)	2.17 m (7 ft. 1 in.)
F Maximum Vertical Wall	3.67 m (12 ft. 0 in.)	4.22 m (13 ft. 10 in.)
G Tail Swing Radius	1.29 m (4 ft. 3 in.)	1.29 m (4 ft. 3 in.)

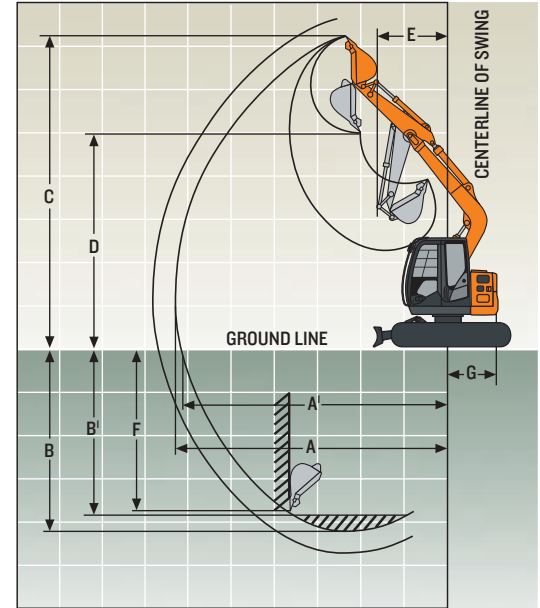

Machine Dimensions

	Arm Length 1.62 m (5 ft. 4 in.)	Arm Length 2.12 m (6 ft. 11 in.)
A Overall Length	6.30 m (20 ft. 8 in.)	6.37 m (20 ft. 11 in.)
B Overall Height	2.69 m (8 ft. 10 in.)	2.69 m (8 ft. 10 in.)
C Undercarriage Width		
With 450-mm (18 in.) Shoes	2.32 m (7 ft. 7 in.)	
With 600-mm (24 in.) Shoes	2.47 m (8 ft. 1 in.)	
D Rear-End Length/Swing Radius	1.29 m (4 ft. 3 in.)	
E Distance Between Idler/Sprocket Centerline	2.29 m (7 ft. 6 in.)	
F Undercarriage Length	2.92 m (9 ft. 7 in.)	
G Counterweight Clearance	0.73 m (29 in.)	
H Cab Height	2.69 m (8 ft. 10 in.)	
I Ground Clearance	360 mm (14 in.)	
J Upperstructure Width	2.32 m (7 ft. 7 in.)	
K Gauge Width	1.87 m (6 ft. 2 in.)	
L Blade Lift Height	360 mm (14 in.)	
Blade Height	480 mm (19 in.)	
Blade Width		
With 450-mm (18 in.) Shoes	2320 mm (7 ft. 9 in.)	
With 600-mm (24 in.) Shoes	2470 mm (8 ft. 1 in.)	
M Blade Cut Below Grade	300 mm (12 in.)	
N Blade Lift Angle	27 deg.	
O Track Width		
With 450-mm (18 in.) Shoes	0.45 m (18 in.)	
With 600-mm (24 in.) Shoes	0.60 m (24 in.)	

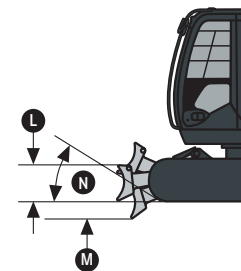
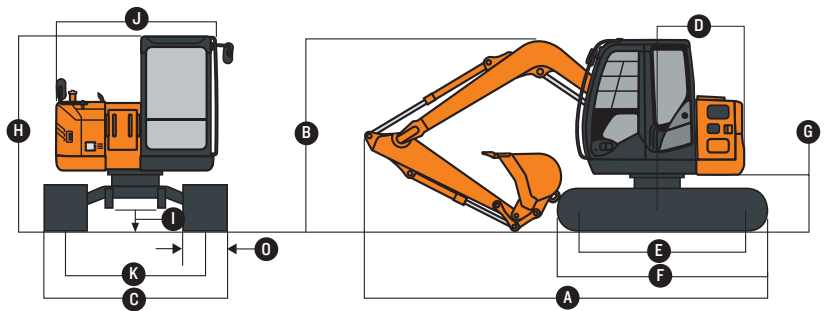

DASH-5

Lift Capacities

Boldface type indicates hydraulically limited capacities; lightface type indicates stability-limited capacities, in kg (lb.). Ratings are at bucket lift hook, using standard counterweight, situated on firm, level, uniform supporting surface. Total load includes weight of cables, hook, etc. Figures do not exceed 87% of hydraulic capacity or 75% of weight needed to tip machine. All lift capacities are based on ISO 10567.

Load Point Height	1.5 m (5 ft.)		3.0 m (10 ft.)		4.5 m (15 ft.)		6.0 m (20 ft.)	
Horizontal Distance from Centerline of Rotation	Over Front	Over Side	Over Front	Over Side	Over Front	Over Side	Over Front	Over Side
With 3.72-m (12 ft. 8 in.) boom, 1.62-m (5 ft. 4 in.) arm, 0.28-m ³ (0.37 cu. yd.) bucket, 450-mm (18 in.) rubber pads, and 2320-mm (7 ft. 9 in.) blade								
4.5 m (15 ft.)			1616 (3,562)	1616 (3,562)				
3.0 m (10 ft.)			2223 (4,901)	2223 (4,901)	1829 (4,032)	1605 (3,539)		
1.5 m (5 ft.)			3192 (7,038)	2752 (6,067)	2121 (4,675)	1538 (3,390)		
Ground Line			3615 (7,969)	2635 (5,810)	2327 (5,131)	1486 (3,275)		
-1.5 m (-5 ft.)	4476 (9,867)	4476 (9,867)	3402 (7,500)	2634 (5,807)				
With 3.72-m (12 ft. 8 in.) boom, 2.12-m (6 ft. 11 in.) arm, 0.28-m ³ (0.37 cu. yd.) bucket, 450-mm (18 in.) rubber pads, and 2320-mm (7 ft. 9 in.) blade								
4.5 m (15 ft.)					1475 (3,252)	1475 (3,252)		
3.0 m (10 ft.)			1834 (4,043)	1834 (4,043)	1613 (3,557)	1613 (3,557)		
1.5 m (5 ft.)			2864 (6,313)	2797 (6,167)	1958 (4,317)	1541 (3,397)		
Ground Line			3508 (7,734)	2629 (5,797)	2248 (4,956)	1472 (3,246)		
-1.5 m (-5 ft.)	3544 (7,813)	3544 (7,813)	3514 (7,746)	2594 (5,718)	2252 (4,964)	1451 (3,199)		
-3.0 m (-10 ft.)	5020 (11,068)	5020 (11,068)	2742 (6,044)	2663 (5,870)				
With 3.72-m (12 ft. 8 in.) boom, 1.62-m (5 ft. 4 in.) arm, 0.28-m ³ (0.37 cu. yd.) bucket, 600-mm (24 in.) shoes, and 2470-mm (8 ft. 1 in.) blade								
4.5 m (15 ft.)			1616 (3,562)	1616 (3,562)				
3.0 m (10 ft.)			2223 (4,901)	2223 (4,901)	1829 (4,032)	1630 (3,594)		
1.5 m (5 ft.)			3192 (7,038)	2796 (6,164)	2121 (4,675)	1563 (3,446)		
Ground Line			3615 (7,969)	2679 (5,906)	2327 (5,131)	1510 (3,330)		
-1.5 m (-5 ft.)	4476 (9,867)	4476 (9,867)	3402 (7,500)	2678 (5,903)				
With 3.72-m (12 ft. 8 in.) boom, 2.12-m (6 ft. 11 in.) arm, 0.28-m ³ (0.37 cu. yd.) bucket, 600-mm (24 in.) shoes, and 2470-mm (8 ft. 1 in.) blade								
4.5 m (15 ft.)					1475 (3,252)	1475 (3,252)		
3.0 m (10 ft.)			1834 (4,043)	1834 (4,043)	1613 (3,557)	1613 (3,557)		
1.5 m (5 ft.)			2864 (6,313)	2841 (6,263)	1958 (4,317)	1566 (3,452)		
Ground Line			3508 (7,734)	2673 (5,893)	2248 (4,956)	1497 (3,301)		
-1.5 m (-5 ft.)	3544 (7,813)	3544 (7,813)	3514 (7,746)	2637 (5,814)	2252 (4,964)	1476 (3,254)		
-3.0 m (-10 ft.)	5020 (11,068)	5020 (11,068)	2742 (6,044)	2707 (5,967)				
With 3.72-m (12 ft. 8 in.) boom, 1.62-m (5 ft. 4 in.) arm, 0.28-m ³ (0.37 cu. yd.) bucket, 450-mm (18 in.) continuous rubber belt, and 2470-mm (8 ft. 1 in.) blade								
3.0 m (10 ft.)			2241 (4,940)	2241 (4,940)				
1.5 m (5 ft.)			3207 (7,070)	2608 (5,750)				
Ground Line			3620 (7,980)	2499 (5,510)	2327 (5,130)	1415 (3,120)		
-1.5 m (-5 ft.)	4527 (9,980)	4527 (9,980)	3393 (7,480)	2499 (5,510)				

Buckets

A full line of buckets is offered to meet a wide variety of applications. Replaceable cutting edges are available through Hitachi Parts. Optional side cutters add 150 mm (6 in.) to bucket widths.

Type Bucket	Bucket Width		Bucket Capacity		Bucket Weight		Bucket Dig Force (ISO)		Arm Dig Force (ISO) 1.62 m (5 ft. 4 in.)		Arm Dig Force (ISO) 2.12 m (6 ft. 11 in.)		Bucket Tip Radius		Number of Teeth
	mm	in.	m ²	cu. yd.	kg	lb.	kN	lb.	kN	lb.	kN	lb.	mm	in.	
Heavy Duty	610	24	0.24	0.31	268	591	44	9,892	34	7,545	29	6,524	883	34.76	5
Heavy Duty	762	30	0.31	0.41	313	691	44	9,892	34	7,545	29	6,524	883	34.76	6
Heavy Duty	914	36	0.39	0.51	358	790	44	9,892	34	7,545	29	6,524	883	34.76	7
Ditching	1219	48	0.49	0.64	330	727	64	14,344	40	8,911	33	7,473	907	35.69	0

Bucket Selection Guide*

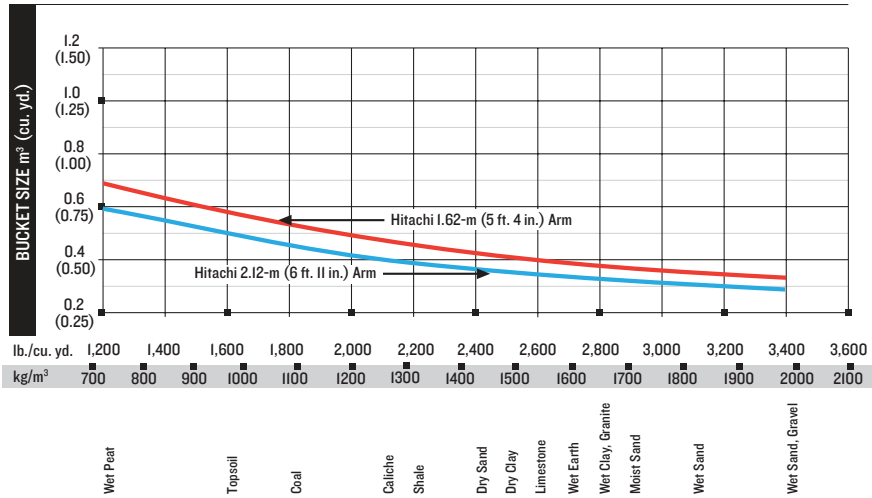

*Contact your Hitachi dealer for optimum bucket and attachment selections. These recommendations are for general conditions and average use. Does not include optional equipment such as thumbs or couplers. Larger buckets may be possible when using light materials, for flat and level operations, less compacted materials, and volume loading applications such as mass-excavation applications in ideal conditions. Smaller buckets are recommended for adverse conditions such as off-level applications, rocks, and uneven surfaces. Bucket capacity indicated is SAE heaped.

DASH-5

ADDITIONAL EQUIPMENT

Key: ● Standard ▲ Optional or special

Engine
● Auto-idle system
● Batteries (2 – 12 volt)
● Coolant recovery tank
● Single-element air filter
● Electronic engine control
● Enclosed fan guard (conforms to SAE J1308)
● Engine coolant to –37 deg. C (–34 deg. F)
● Fuel filter with water separator
● Full-flow oil filter
● Radiator and oil cooler with dust-protective net
● Glow-plug start aid
● 500-hour engine oil-change interval
● 70% (35 deg.) off-level capacity
● Isolation mounted
Hydraulic System
● Reduced-drift valve for boom down, arm in
● Auxiliary hydraulic valve section
● Spring-applied, hydraulically released automatic swing brake
● Auxiliary hydraulic-flow adjustments through monitor
● 5,000-hour hydraulic-oil-change interval
▲ Auxiliary hydraulic lines
▲ Auxiliary pilot and electric controls
▲ Hydraulic filter restriction indicator kit
▲ Load-lowering control device
▲ Single-pedal propel control
▲ Control pattern change valve
Undercarriage
● Planetary drive with axial piston motors
● Propel motor shields
● Spring-applied, hydraulically released automatic propel brake
● 2-speed propel with automatic shift
● Upper carrier roller (1)
● Sealed and lubricated track chain
● Undercarriage with blade
▲ Triple semi-grouser shoes, 450 mm (18 in.)
▲ Triple semi-grouser shoes, 600 mm (24 in.)
▲ Rubber crawler pads, 450 mm (18 in.)
▲ Rubber belt, continuous, 450 mm (18 in.)

Upperstructure
● Counterweight, 1305 kg (2,877 lb.)
● Right- and left-hand mirrors
● Vandal locks with ignition key: Cab door / Engine hood / Fuel cap / Service doors
● Remote-mounted engine oil and fuel filters
Front Attachments
● Centralized lubrication system
● Dirt seals on all bucket pins
● Less boom and arm
● Oil-impregnated bushings
● Reinforced resin thrust plates
● Tungsten carbide thermal coating on arm-to-bucket joint
▲ Arm, 1.62 m (5 ft. 4 in.)
▲ Arm, 2.12 m (6 ft. 11 in.)
▲ Attachment quick-couplers
▲ Buckets: Ditching / Heavy duty / Heavyduty high capacity / Side cutters and teeth
Operator's Station
● Meets ISO 12117-2 for ROPS
● Adjustable independent control positions (seat-to-pedals)
● AM/FM radio
● Auto climate control/air conditioner with heater and pressurizer
● Built-in operator's manual storage compartment and manual
● Cell-phone power outlet, 12 volt, 60 watt, 5 amp
● Coat hook
● Deluxe cloth suspension seat with adjustable armrests
● Floor mat
● Front windshield wiper with intermittent speeds
● Gauges (illuminated): Engine coolant / Fuel
● Horn, electric
● Hour meter, electric
● Hydraulic shutoff lever, all controls
● Hydraulic warm-up control
● Interior light
● Large cup holder
● Machine Information Center (MIC)

Operator's Station (continued)
● Mode selectors (illuminated): Power modes (2) / Travel modes (2 with automatic shift) / Work mode (1)
● Multifunction, color LCD monitor with: Diagnostic capability / Multiple-language capabilities / Maintenance tracking / Clock / System monitoring with alarm features: Auto-idle indicator, engine air cleaner restriction indicator light, engine check, engine coolant temperature indicator light with audible alarm, engine oil pressure indicator light with audible alarm, low-alternator-charge indicator light, low-fuel indicator light, fault-code alert indicator, fuel-rate display, wiper-mode indicator, work-lights-on indicator, and work-mode indicator
● Motion alarm with cancel switch (conforms to SAE J994)
● Auxiliary hydraulic control switches in right console lever
● SAE 2-lever control pattern
● Seat belt, 51 mm (2 in.), retractable
● Tinted glass
● Transparent tinted overhead hatch
● Hot/cold beverage compartment
▲ Seat belt, 76 mm (3 in.), non-retractable
▲ Protection screens for cab front, rear, and side
▲ Window vandal-protection covers
Electrical
● 50-amp alternator
● Blade-type multi-fused circuits
● Positive-terminal battery covers
▲ ZXLink™ wireless communication system (available in specific countries; see your dealer for details)
Lights
● Work lights: Halogen / 1 mounted on boom / 1 mounted on frame

See your Hitachi dealer for further information.

Net engine power is with standard equipment including air cleaner, exhaust system, alternator, and cooling fan at test conditions specified per ISO 9249. No derating is required up to 3050-m (10,000 ft.) altitude. Specifications and design subject to change without notice. Wherever applicable, specifications are in accordance with SAE standards. Except where otherwise noted, these specifications are based on unit with standard equipment; 0.31-m³ (0.41 cu. yd.), 762-mm (30 in.), 313-kg (691 lb.) bucket; 450-mm (18 in.) rubber crawler pad shoes; 2.12-m (6 ft. 11 in.) arm; full fuel tank; and 75-kg (165 lb.) operators; 1305-kg (2,877 lb.) counterweight.

HITACHI

hitachiconstruction.com